

INSTRUCTION SHEET

Diffused Metal Halide Kit for Vertical Mast MLTs

Overview

These instructions illustrate installation of the Diffused Metal Halide Kit. This kit is not compatible with LED lights or LED light towers.

NOTE: It is necessary to enlist the help of an assistant during kit assembly.

Models Affected

- Select 6S series MLTs
- Select 3000V-, 4000V-, and 5000V-series MLTs



WARNING

Consult Manual. Read and understand manual completely before using product. Failure to completely understand manual and product could result in death or serious injury. (000100a)

WARNING

Equipment damage. Only qualified service personnel may install, operate, and maintain this equipment. Failure to follow proper installation requirements could result in death, serious injury, and equipment or property damage. (000182a)

Kit Components

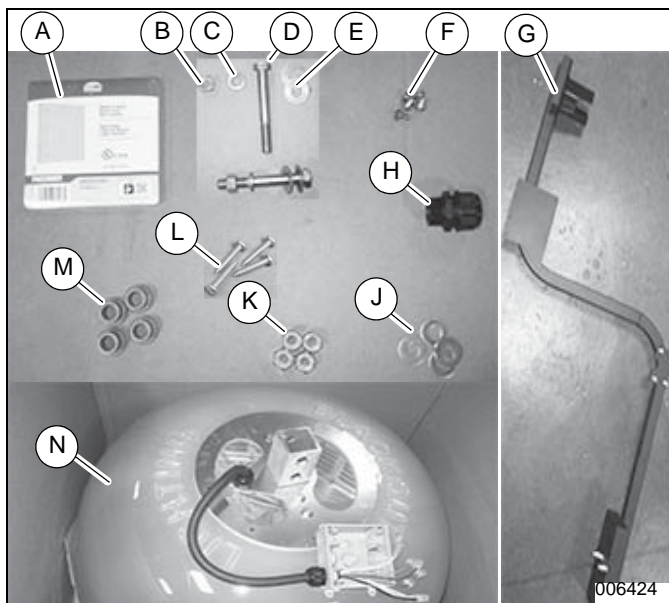

Item	PN	Qty	Description
—	10000022548	1	Instructions
A	12109	1	COVER,BOX,2 GANG,PLSTC
B	61093	2	NUT, .500-13 HEX G8 ZB
C	60276	2	WASHER, .500 SPLIT LOCK ZC
D	50215	2	SCREW, .500-13X4.000 STD HEX G5 ZC
E	60670	4	WASHER, .500 FLAT 1.060/ .110 ZC, G8
F	10000024270	5	SCREW 10-32 X .500 TRUSS PHIL 18-8 SS
G	One of the following:		
	10000022727	1	WELDMENT DROP FRAME LIGHT MOUNT
	10000023766	1	WELDMENT BRACKET MNT 3000-5000 VERT MAST
H	14656	1	STRAIN RLF, .75 NPT .545/ .709 ID, WT
J	60151	4	WASHER, .375 FLAT .810/ .060 ZY HARDENED
K	60358	4	NUT, .375-16 NYLK G5 ZC
L	60424	4	SCREW, 6-32X.750 PAN PHIL G2 ZC
M	10000022794	4	BEARING .75 OD X .5 ID X .5 L X 1 FLANGE
N	10000022742	1	ASSY MH DIFFUSED LIGHT FIXTURE
MLT 3000-4000-5000 kits only:			
—	60400	4	SCREW, .375-16X3.000 STD HEX G5 ZC

Recommended Tools

- Step ladders, lift, or platform
- Cross-blade screwdriver
- Combination wrenches—5/16, 7/16, 3/4, 9/16, 11/16, 1-1/8 in.
- Clean gloves
- Clean towel

Installation: MLT6S

NOTE: See page 6 for other vertical mast MLTs.

Preparing Unit for Service



WARNING

Burn hazard. Lamps become extremely hot while in use. Allow 10–15 minutes for cooling before handling or lowering mast. Touching a hot lens or fixture can cause severe burns.

(000278)

1. Fully retract mast.
2. Place unit on firm, flat surface.
3. Block wheels.
4. Verify unit is OFF, the engine is cool, and the lamps are cool.
5. Disconnect negative (-) battery cable.

Removing Standard Equipment

Unless specified, parts removed in this section do not need to be retained for later installation.

1. See [Figure 1](#). Remove lid of junction box.

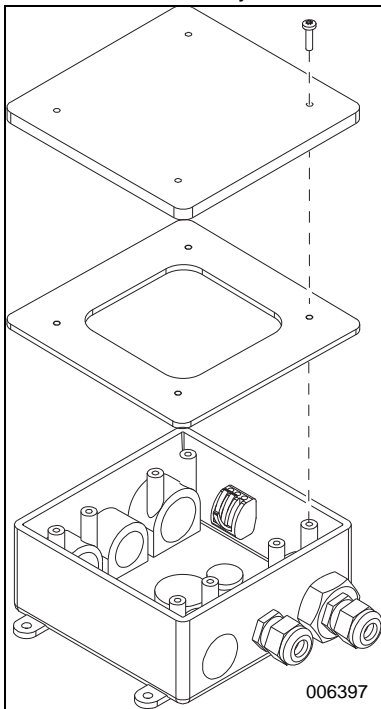

Figure 1. Junction Box Lid Removal

2. Disconnect all wires in junction box.
3. Loosen strain reliefs securing light cables.

NOTE: Do not loosen strain relief securing coil-cord until instructed.

4. Remove light cords from junction box.
5. Remove junction box from mast.
6. Loosen strain relief securing coil-cord.
7. Remove coil-cord from junction box.

8. See [Figure 2](#). Remove light fixtures from crossbar.

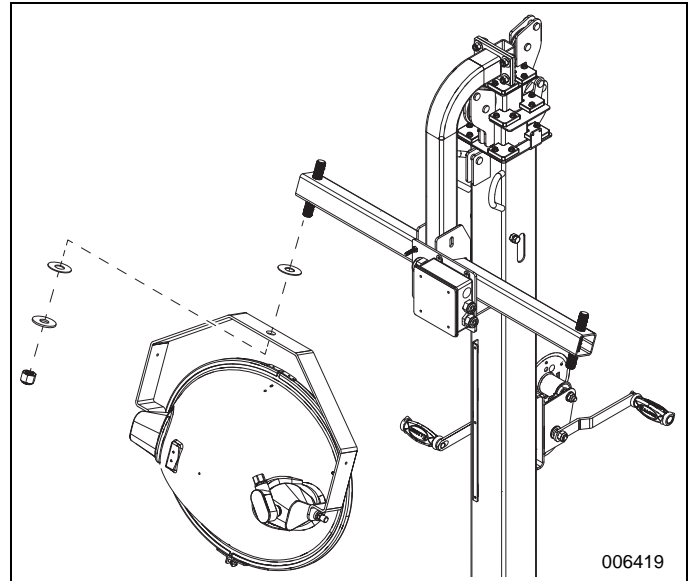

Figure 2. Light Fixture Removal

9. See [Figure 3](#). Remove bulbs from light fixtures: Remove hardware (A), lid (B), and gasket (C). Unfasten bulb support (D). Remove and retain bulb.

IMPORTANT NOTE: When checking or replacing the bulbs, wipe them with a clean cloth to avoid leaving any residue or fingerprints on the glass. Residue can result in a hot spot on the bulb and result in premature bulb failure.

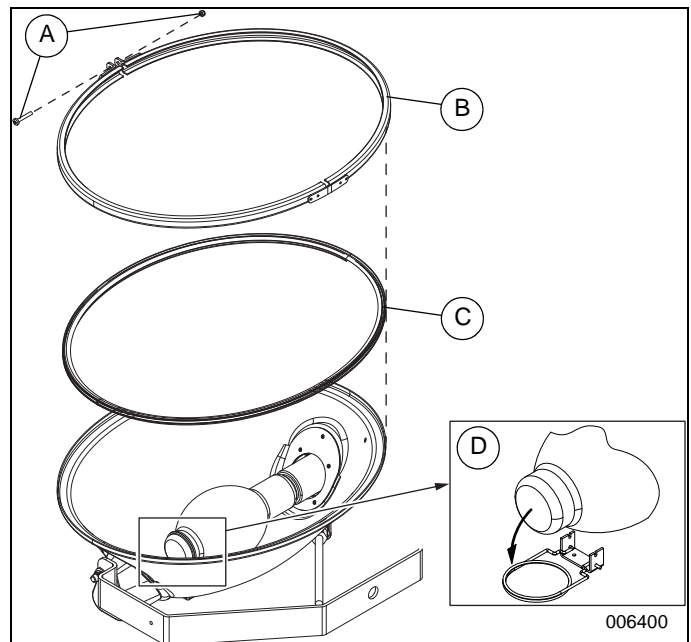

Figure 3. Bulb Removal

10. See [Figure 4](#). Remove crossbar from mast.

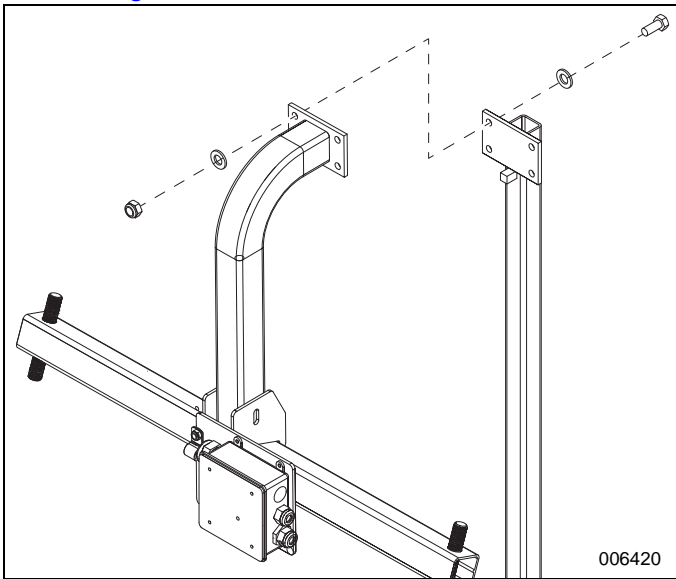

Figure 4. Crossbar Removal

11. See [Figure 5](#). Remove and retain tubing clamp (A).

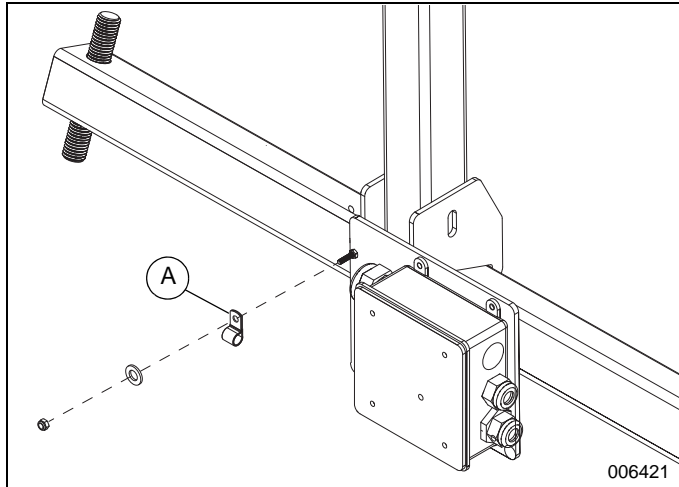

Figure 5. Tubing Clamp Removal

Installing Metal Halide Kit

1. See [Figure 6](#). Install mounting weldment (A) to mast. Tighten hardware to 20 ft-lb (27.2 Nm).

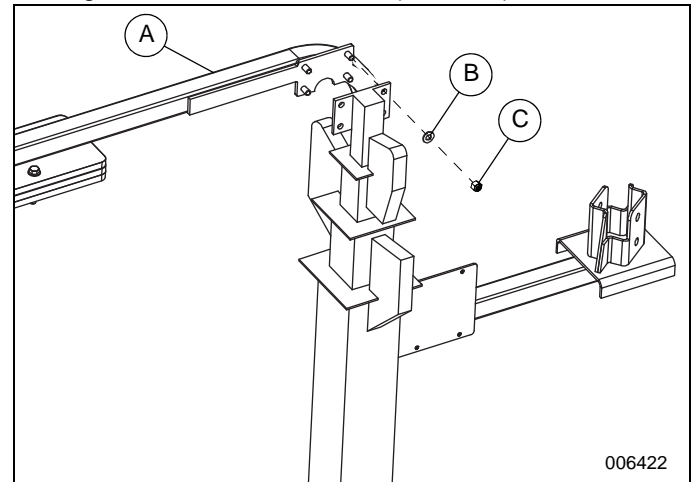

Figure 6. Mounting Weldment Installation

Item	Kit PN	Description
A	10000022727	Weldment, drop frame, light mount
B	60151	Washer, .375 flat .180/.060 ZY hardened
C	60358	Nut, .375-16 NYLK G5 ZC

2. See [Figure 7](#). Obtain light fixture (A). Remove and retain hardware securing sides of lid.

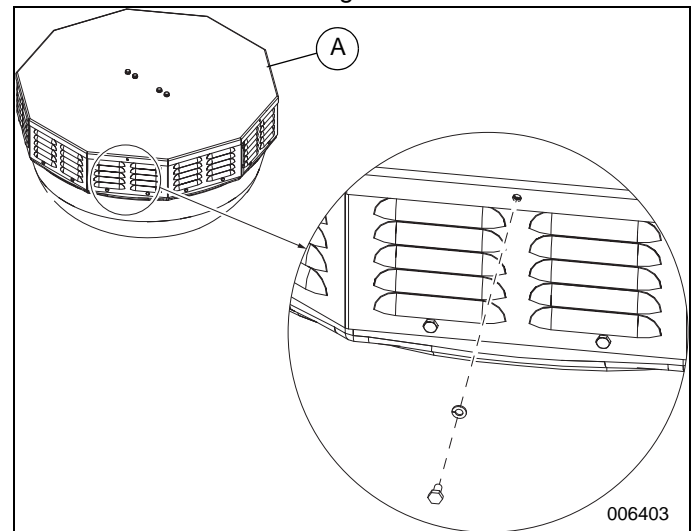

Figure 7. Hardware Removal—Side of Lid

Item	Kit PN	Description
A	10000022742	Assembly, light fixture

- See **Figure 8**. Remove and retain hardware securing top of lid. Remove and retain lid.

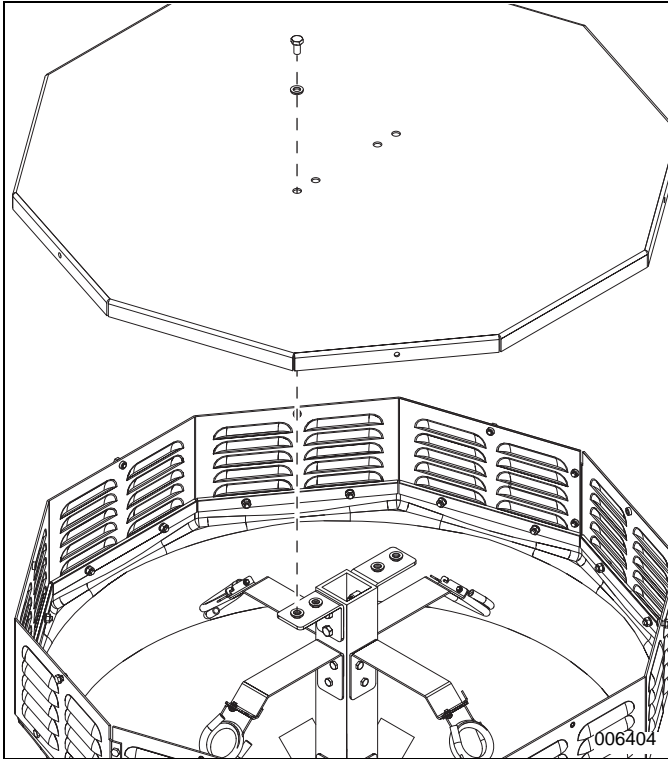

Figure 8. Lid Removal

IMPORTANT NOTE: When checking or replacing the bulbs, wipe them with a clean cloth to avoid leaving any residue or fingerprints on the glass. Residue can result in a hot spot on the bulb and result in premature bulb failure.

- See **Figure 9**. Install bulbs, as follows.

Pinch at (A) to release spring-clamp brace. Pivot as illustrated (B). Install bulb (C). Secure bulb with spring-clamp brace as shown (D).

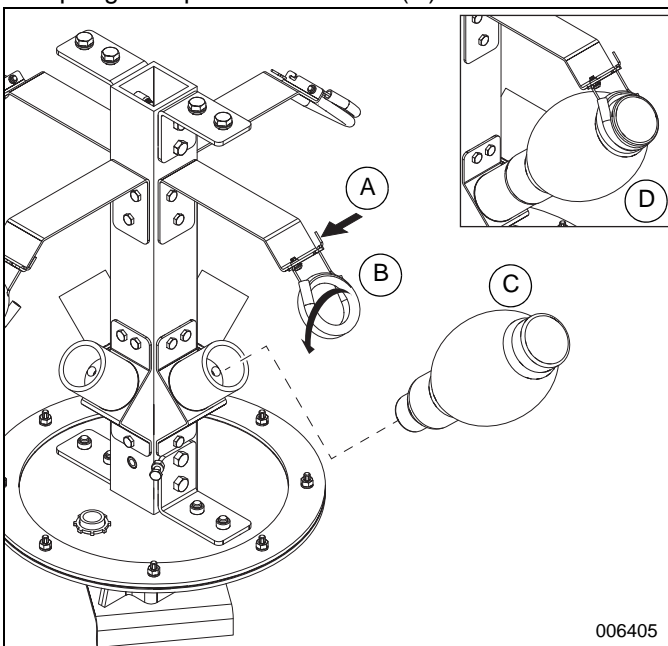

Figure 9. Bulb Installation

- Install lid to new light fixture, as follows.

IMPORTANT NOTE: Excessive torque can strip screw heads and damage threads.

- See **Figure 8**. Install lid using hardware retained in step 3, lubricating surfaces of rubber washers before installing. Tighten hardware to 19.7 ft-lb (26.7 Nm).
 - See **Figure 7**. Install hardware retained in step 2. Tighten to 75 in-lb (8.5 Nm).
- See **Figure 10**. Install bearings (A) to light fixture. Arrange light fixture so strain relief (B) faces away from mast.

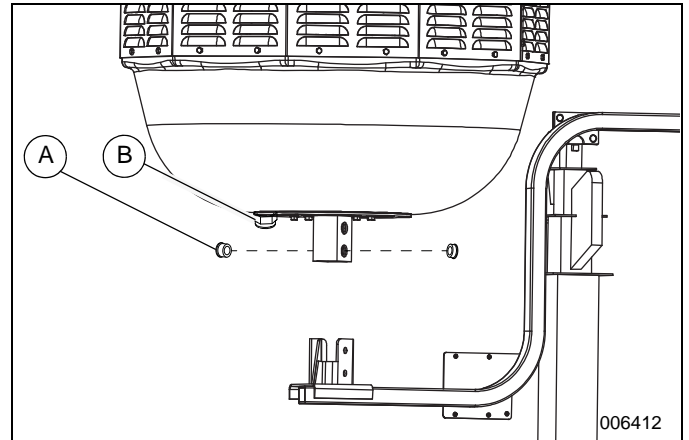

Figure 10. Bearing Installation; Proper Light Position

Item	Kit PN	Description
A	10000022794	Bearing .75 OD X .5 ID X .5 L X 1
B	—	[part of light fixture]

- See **Figure 11**. Install light fixture to mounting weldment. Tighten hardware to 43 ft-lb (58.3 Nm).

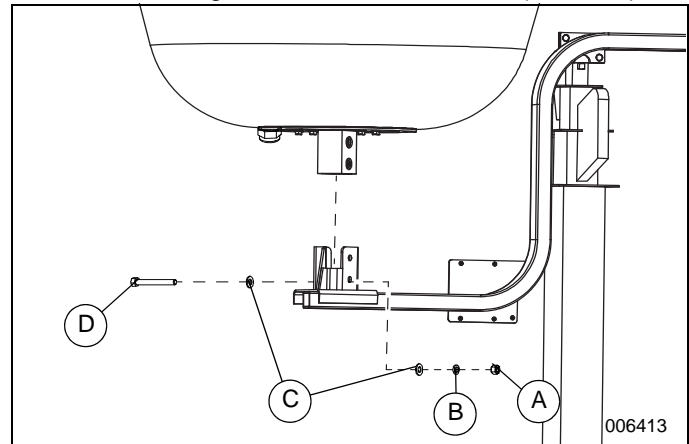

Figure 11. Light-to-Bracket Installation

Item	Kit PN	Description
A	61093	Nut, .500-13 hex G8 ZB
B	60276	Washer, .500 split lock ZC
C	60670	Washer, .500 flat 1.060/.110 ZC,G8
D	50215	Screw, .500-13X4.000 STD hex G5 ZC

8. See [Figure 12](#). Install strain relief to junction box. Install coil-cord to tubing clamp, then install tubing clamp as shown.

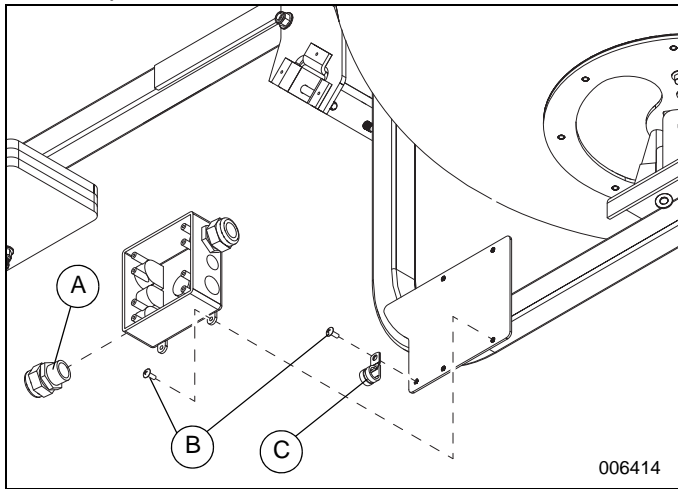

Figure 12. Junction Box Installation

Item	Kit PN	Description
A	14656	Strain relief
B	—	Tubing clamp—retained in step 6 of Removing Standard Equipment .
C	10000024270	Screw 10-32 X .500 truss phil 18-8 SS

9. See [Figure 13](#). Install coil-cord through lower strain relief (A). Verify enough wire is in junction box to connect to WAGO connectors, then tighten strain relief.

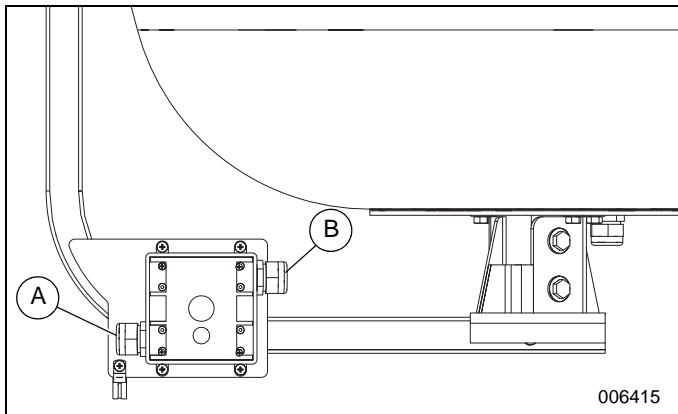

Figure 13. Cable Installation

10. Install light fixture cord through upper strain relief (B). Verify enough wire is in junction box to connect to WAGO connectors, then tighten strain relief.

11. See [Figure 14](#). In junction box, connect wires.

LIGHT TOWER	LIGHT
BLK	BLK
WHT	WHT/BLK
	WHT/RED
RED	RED
BLUE	BLUE
BROWN	WHT/BLUE
	WHT/ORG
YELLOW (or ORANGE)	ORANGE
GREEN (GROUND)	GREEN

006417

Figure 14. Junction Box Wiring

12. See [Figure 15](#). Install junction box cover.

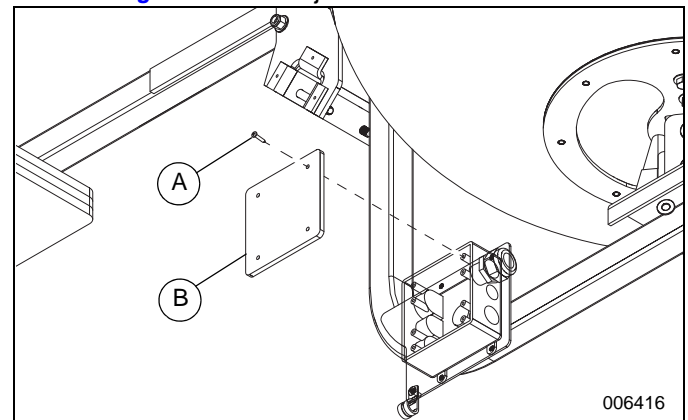

Figure 15. Junction Box Cover Installation

Item	Kit PN	Description
A	60424	Screw, 6-32x.750 pan phil G2 ZC
B	12109	Cover, box, 2 gang, plstc

Diffused Metal Halide Kit installation is complete.

Installation: Other Vertical Mast MLTs

Preparing Unit for Service



WARNING

Burn hazard. Lamps become extremely hot while in use. Allow 10–15 minutes for cooling before handling or lowering mast. Touching a hot lens or fixture can cause severe burns.

(000278)

1. Fully retract mast.
2. Place unit on firm, flat surface.
3. Block wheels.
4. Verify unit is OFF, the engine is cool, and the lamps are cool.
5. Disconnect negative (-) battery cable.

Removing Standard Equipment

Unless specified, parts removed in this section do not need to be retained for later installation.

1. See [Figure 1](#). Remove lid of junction box.
2. Inside junction box, disconnect all wires, then loosen strain reliefs, then remove all wires from box.
3. See [Figure 16](#). Remove light fixtures (A). Remove crossbar (B). Remove junction box (C).

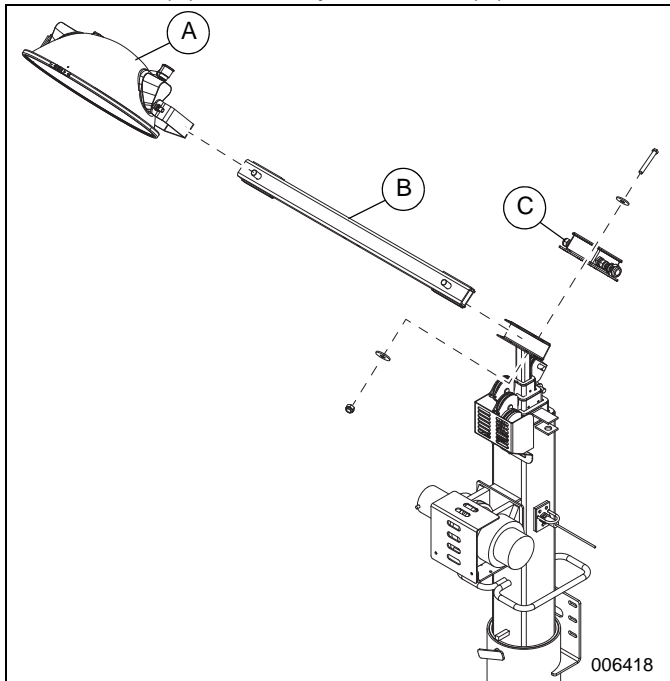

Figure 16. Light Fixture and Crossbar Removal

IMPORTANT NOTE: When checking or replacing the bulbs, wipe them with a clean cloth to avoid leaving any residue or fingerprints on the glass. Residue can result in a hot spot on the bulb and result in premature bulb failure.

4. See [Figure 3](#). Remove bulbs from light fixtures as follows: Remove hardware (A). Remove lid (B) and gasket (C). Unfasten bulb support, as illustrated (D). Finally, remove and retain bulb.
5. See [Figure 17](#). Remove and retain tubing clamp (A).

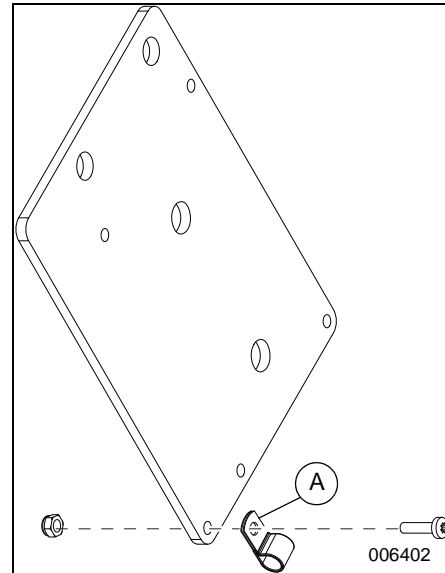

Figure 17. Tubing Clamp Removal

Installing Metal Halide Kit

- See [Figure 18](#). Install new mounting weldment. Tighten hardware to 20 ft-lb (27.2 Nm).

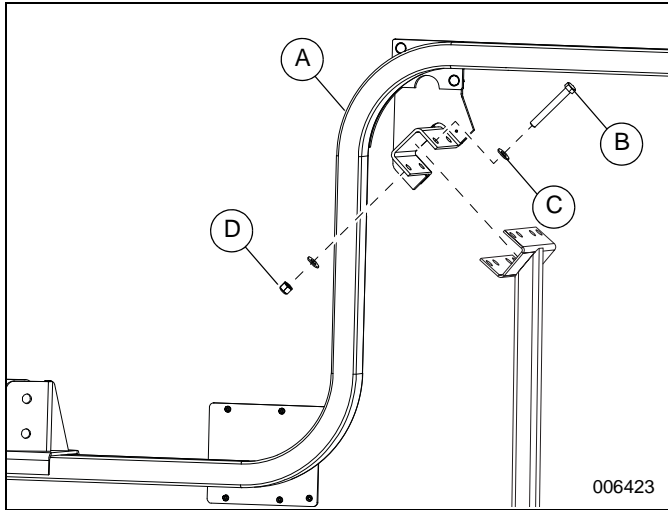

Figure 18. Bracket Installation

Item	PN	Description
A	10000023851	Assy bracket MNT 3000-5000 vert mast
B	60400	Screw, .374016 x 3/000 std hex G5 ZC
C	60151	Washer, .375 flat .810/.060 ZY hardened
D	61093	Nut, .500-13 hex G8 ZB

- See [Figure 7](#). On the light fixture, remove and retain hardware securing sides of lid.
- See [Figure 8](#). On the light fixture, remove and retain hardware securing top of lid. Remove and retain lid.

IMPORTANT NOTE: When checking or replacing the bulbs, wipe them with a clean cloth to avoid leaving any residue or fingerprints on the glass. Residue can result in a hot spot on the bulb and result in premature bulb failure.

- See [Figure 9](#). Install bulbs, as follows.
Pinch at (A) to release spring-clamp brace. Pivot as illustrated (B). Install bulb (C). Secure bulb with spring-clamp brace as shown (D).

- Install lid to new light fixture, as follows.

IMPORTANT NOTE: Excessive torque can strip screw heads and damage threads.

- See [Figure 8](#). Install lid using hardware retained in step 3, lubricating surfaces of rubber washers before installing. Tighten hardware to 19.7 ft-lb (26.7 Nm).
 - See [Figure 7](#). Install hardware retained in step 2. Tighten to 75 in-lb (8.5 Nm).
- See [Figure 10](#). Install bearings (A) to light fixture. Arrange light fixture so strain relief (B) faces away from mast.
 - See [Figure 11](#). Install light fixture to mounting weldment. Tighten hardware to 43 ft-lb (58.3 Nm).
 - See [Figure 12](#). Install strain relief to junction box. Install coil-cord to tubing clamp, then install tubing clamp as shown.
 - See [Figure 13](#). Install coil-cord through lower strain relief (A). Verify enough wire is in junction box to connect to WAGO connectors, then tighten strain relief.
 - See [Figure 13](#). Install light fixture cord through upper strain relief (B). Verify enough wire is in junction box to connect to WAGO connectors, then tighten strain relief.
 - See [Figure 14](#). In junction box, connect wires.
 - See [Figure 15](#). Install junction box cover.

Diffused Metal Halide Kit installation is complete.